

# HyperFront QR15

## Features

HyperFront offers unique features like low friction external OR seals, front engagement freewheel system, multishaped oversized axle, top quality sealed ball bearings, Micro-Tuner bearing preload system, "hart coat" anodized cassette body and axle ends.

Use it proper care and its absolute performance will last for years. This manual provides the informations needed for the set up and the basic cleaning-lubing-maintenance.

Destination X-Country use.

## Dimension for wheel building

Spoke hole Ø: 2.5mm  
Right flange drilling Ø: 32mm  
Disc flange drilling Ø: 54mm  
Center to right flange: 39mm  
Center to disc flange: 23mm

## Lacing

To insert radial spokes follow "Seals and hub internal cleaning" procedure and insert spokes after point 2).  
Respect 24h, 28h or 32h lacing patterns.  
See [www.extralite.com](http://www.extralite.com) to find pre-calculated spoke lengths.

## maximum spoke tension

Disc side 110kgf +/- 10kgf  
Right side 70kgf +/- 10kgf

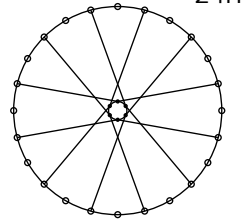

24H

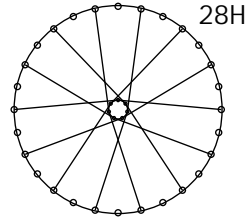

28H

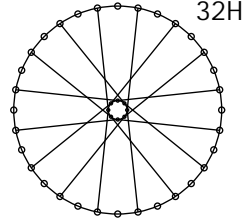

32H



## Bearing preload set-up:

Optimal bearing preload is important for a long bearing life. Micro Tuner comes pre-adjusted from the factory. Do not modify its position if not necessary.

### Checking

Before modifying bearing preload carefully check the complete wheel as follows:

- 1) Install wheel into dropouts and normally lock skewer.
- 2) Check there is no play at rim diameter.
- 3) Leave wheel free to completely stop spinning and carefully control latest instants of movement. Stopping should be very smooth.

### Preload Tuning

If necessary fine tune as follows.

- 1) Install wheel into dropouts and normally lock skewer.
- 2) If you feel play at the rim turn in Micro-Tuner (clockwise). Use a 21mm wrench, very delicate torque and manners.
- 3) Unscrew Micro-Tuner for ca 1/4 of turn to release excessive preload on bearing balls and achieve max rolling smoothness.
- 4) Repeat Preload Checking and eventually slightly correct it.
- 5) The optimal bearing preload cancels play at the rim without affecting rolling smoothness.

Warning Incorrect bearing preload can damage bearings and freewheel parts additionally decreases hub performance.

Sealing HyperRear hub features low friction external OR seals. However, since it is impossible to completely seal a hub and still have it spin freely, with use water/moisture can get in.

Guideline Periodically clean hub internals (every 6-12 months in normal and dry conditions, every 3 months in wet conditions and always before leaving the wheel un-used for more than 1 month) see Level1 instructions next page.

Never use high-pressure spray washing directly on hubs. Clean hubs externally with warm water and soap.

**WARNING** Water and moisture stagnant inside hub can permanently damage bearings.

## Hyper front Maintenance (level 1).

### Seals and hub internal cleaning

Periodically clean seals and hub internals, since water and moisture stagnant inside hub will damage bearings in few weeks.

- 1) Pop out Right Axle End with External OR (23x1.5)
- 2) Extract Axle Assembly and External OR (27x1.5) from right side.
- 3) Clean hub internals and all parts (Do not use aggressive solvents).
- 4) Apply grease on Axle bearing contact areas.
- 5) Fill up Micro Tuner internal face with soft grease.
- 6) Insert Axle Assembly from Left side, gently push it in with using the small plastic mallet.
- 7) Fill up Right Axle End internal face with soft grease.
- 8) Gently pop in Right Axle End with the plastic mallet while Left Axle End is rested against a wood or plastic surface.
- 9) Check Preload Tuning (see Bearing Set-Up chapter).
- 10) Install External OR (27x1.5 oiled) between Micro Tuner and bearing.
- 11) Install External OR (23x1.5 oiled) between Right Axle End and bearing.

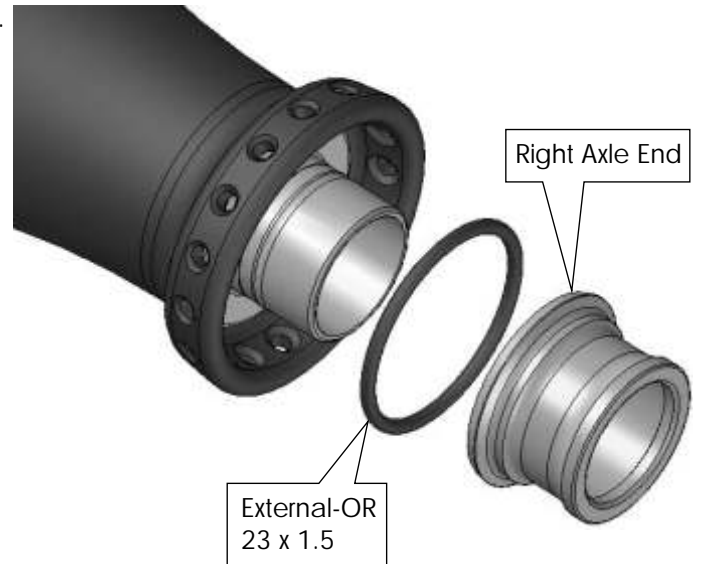

Warning: install External Orings only when the hub is completely assembled and tuned.

### Right spoke replacement.

To insert radial spokes follow "Seals and hub internal cleaning" procedure and insert spokes after point 2).

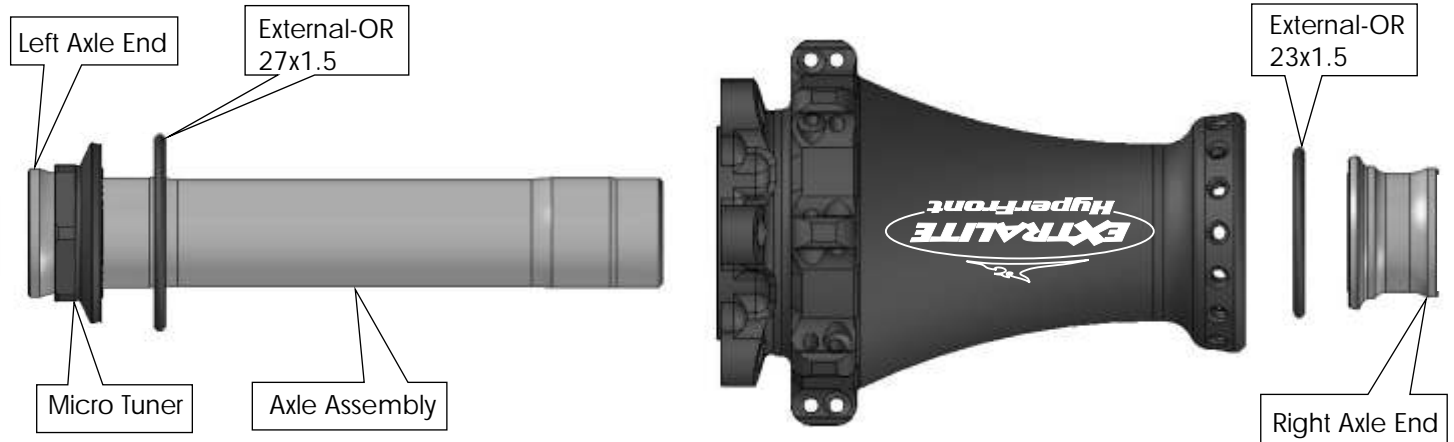

# EXTRALITE

## Extralite Limited Warranty

Extralite products are warranted against defects in materials and/or workmanship for a period of two years from original date of purchase to the original owner only.

Any Extralite product that is returned and found by Studio Riva to be defective in materials and/or workmanship will be repaired or replaced at the sole discretion of Studio Riva. This warranty is the sole and exclusive remedy. Studio Riva shall not be held liable for any indirect, special or consequential damages. The warranty is expressly limited to repair or replacement of the product that has been returned and found to be defective by Studio Riva and are the sole remedy of the warranty. No credits or refunds will be issued.

The warranty does not cover: normal wear, tear and fatigue; damage or failure due to accident or collision. Improper assembling, poor maintenance, alterations or modifications, installation of parts not compatible with Extralite products void this warranty. Warranty does not cover damage arising from crash, abuse and/or misuse or any other circumstances in which the product had been subjected to forces or loads beyond its design.

Immediately replace the component after crash and violent shock, or after continuous heavy use.

Improper use, modification and/or part changing, including surface finishing, could irreparably damage the component.

All labor charges for warranty service are responsibility of the product owner.

### INSTALLATION WARNING:

Extralite components are extremely performing and lightweight, crafted with very high quality, they request adequate installation and maintenance care. We strongly recommended that a professional bike shop install and service your Extralite components.

Improper assembly and/or adjustment may significantly compromise strength and durability of the component causing serious personal injury.

Carefully check proper tightening torque of every bolt. Always respect installation recommendations.

Extralite components are designed for a specific use X-Country or Road or Downhill, respect product specific destination.

Note: the rider assumes all the risks regarding use and installation of Extralite components.