

E-Bones W

BB30 - 73mm

Read carefully instruction before installation

FRAME PREPARATION

Prepare BB shell:

- 1) BB shell faces should be parallel, $\pm 0.05\text{mm}$ tolerance.
- 2) BB shell faces should be at $73 \pm 0.2\text{mm}$.
Eventually file faces with appropriate tool.
- 3) Moisture draining: drill $\varnothing 3.5$ to 5mm drain hole.
Drilling might be not necessary on sealed BB shell of monocoque frames.

Uncorrect / incomplete 1,2,3 set-ups can significantly reduce bearing life and performance.

DRIVE CRANK PREPARATION

Assemble chainrings on the right crank.

On 3x9 MTB models apply granny spacers (orange) between 22 chainring and spider (pict.1).

Respect chainring alignment marks for correct shifting performance.

INSTALLATION

Snap Bearings into BB 30 Bearing cups by hand.

Grease frame and BB 30 bearing cup contact areas

Use a common headset installation tool with supplied Mounting Rings to protect bearing races.

See drawing for correct Mounting Rings positioning.

Press-fit BB 30 bearing cups. Remove Mounting Rings.

Grease threads, bearings contact areas and Hexagonal cone.

Insert right crank axle through bearings.

Fully turn in (counterclockwise) bearing preloader (FIRM direction) by hand, then loose it (clockwise) $1/4$ to $1/2$ turn.

Insert Locking OR on axle.

Align left crank on axle, grease bolt head contact area and tight it (15Nm).

Check bearing preload (see next page).

FEATURES

Weight: 498gr. (Set)

Compatibility: BB30 73mm BB shell.

Chainline: 50.2mm

Q-Factor: 165mm

Destination: X-Country use.

SSP
Stress Split Profile
int. pat. pending

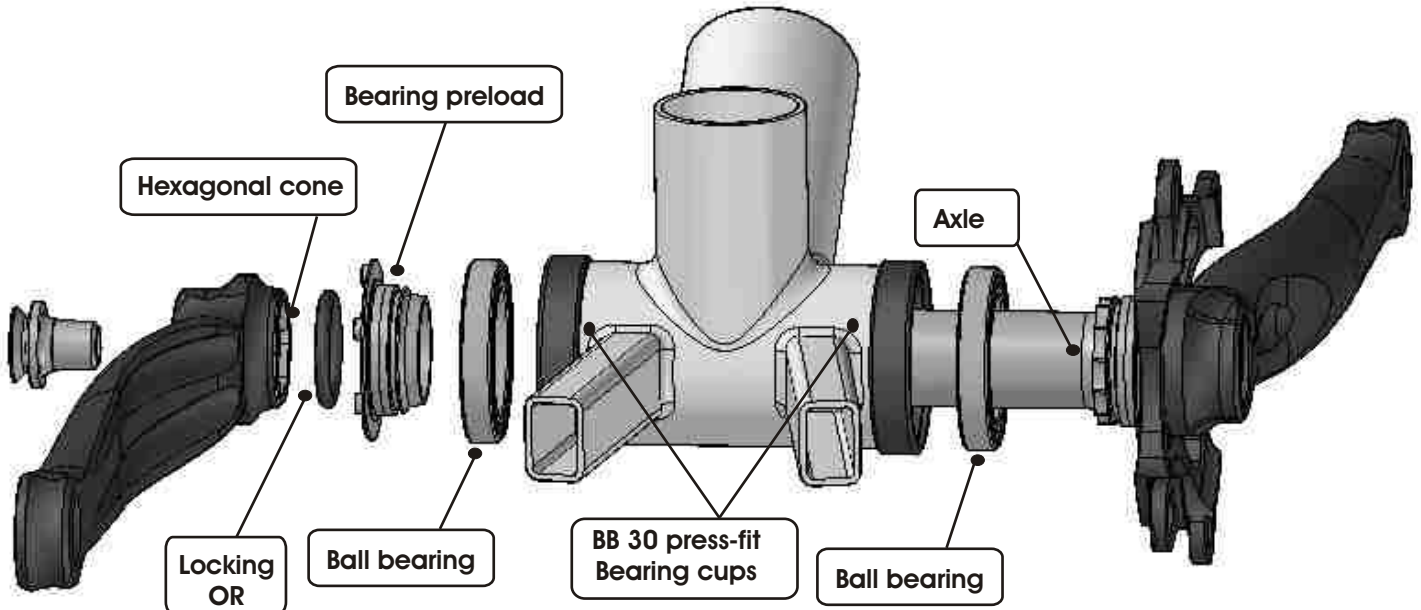
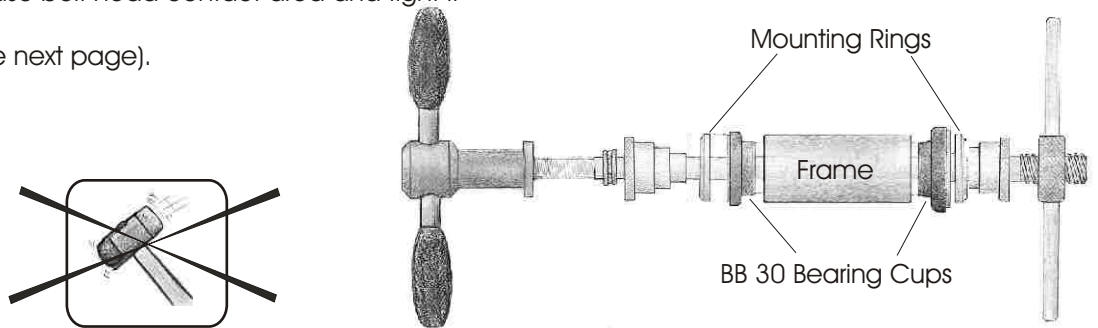
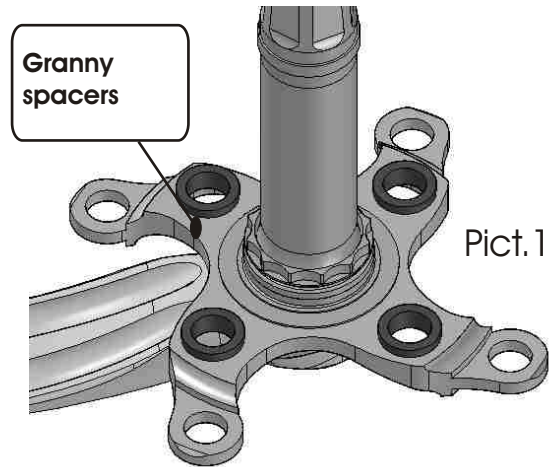

BEARINGS PRELOAD

Bearing preloader allows you to adjust axial preloading.
Use supplied tool to adjust preloader after complete crank assembling.

Use it as follows:

<-- FIRM to correct axial play.

LOOSE --> to increase rolling smoothness.

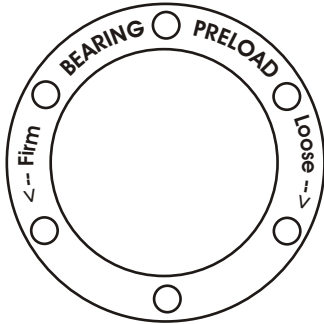

Shake crank-end to check BB play.

Optimal tuning cancels axial play without adding any rolling resistance.

WARNING: incorrect bearing preload may seriously damage bearings/parts and decreases performance.

REMOVAL

To disassemble crankset proceed as follows:

Unscrew axle bolt. Remove left crank using ISIS type extractor only. **WARNING: JIS extractors may damage axle thread!**

Fully unscrew (clockwise) Bearing preloader (Loose direction).
Extract right crank and axle.

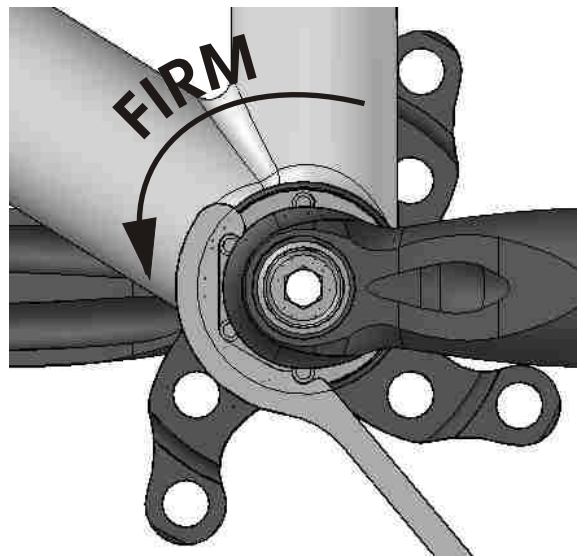
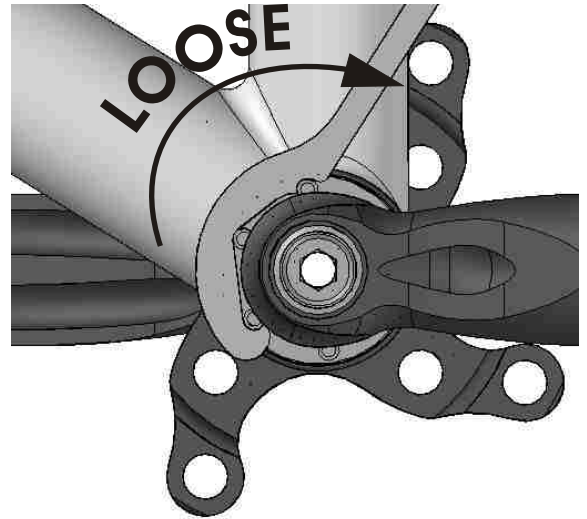

Studio Riva Srl - Tel: ++39-0371-203059 - Fax: ++39-0371-203754
email: studioriva@extralite.com - www.extralite.com

EXTRALITE