

UltraStar3

FEATURES:

Fits alloy or carbon 1 1/8" steer tubes with 22.8 to 25.2 mm internal diameter.

Fits standard M6 top cap bolts.

O-Ring: 2x18mm.

Destination: Road, Cyclo-cross, X-Country, Trail ride.

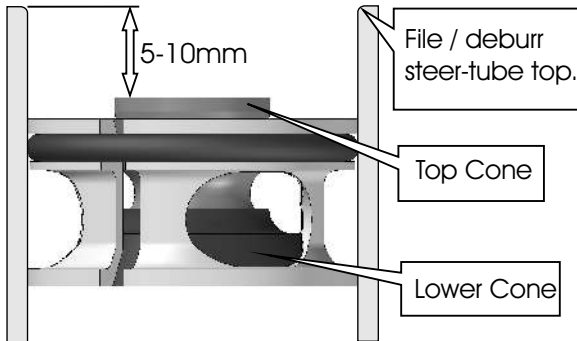

INSTALLATION:

File the top of the steer-tube to avoid sharp edges.

Hold Lower Cone with your fingers.

Use 8mm allen key to screw in Top Cone until you can fully insert UltraStar3 into the steer tube with mild hand pressure.

Insert and tighten UltraStar3 (7-8Nm) in the steer tube at 5 to 10mm from the top.

WARNINGS:

UltraStar3 should be used for headset preload tuning only.

On carbon fiber steer tubes never install UltraStar3 without a stem properly locked.

Always remember to tighten stem clamp before riding.

(Respect manufacturer recommended torque).

UltraStar3 cannot hold a loose stem while riding.

EXTRALITE