

# CyberRear SPD 2/3 N3W conversion Kit (Not for SPD 3+)

## INTRODUCTION

Special skills and attention are required to properly execute tolerance check and tuning.

Refer to Level 1 maintenance for basic informations.

**Warning:** Use only very soft density pure grease as original Alugrease Super1, medium or hard density grease may cause un-complete pawl engagement and this will seriously damage freewheel mechanism. Most greases contain chemical additives that may damage OR Seals and, most of all, can break the freewheel OR spring.

**Warning:** CyberRear mechanisms are suitable for road and cyclocross use (and not MTB), **shortest gear ratio 1.00**. Shorter ratios may result in high torque and damage freewheel mechanism.

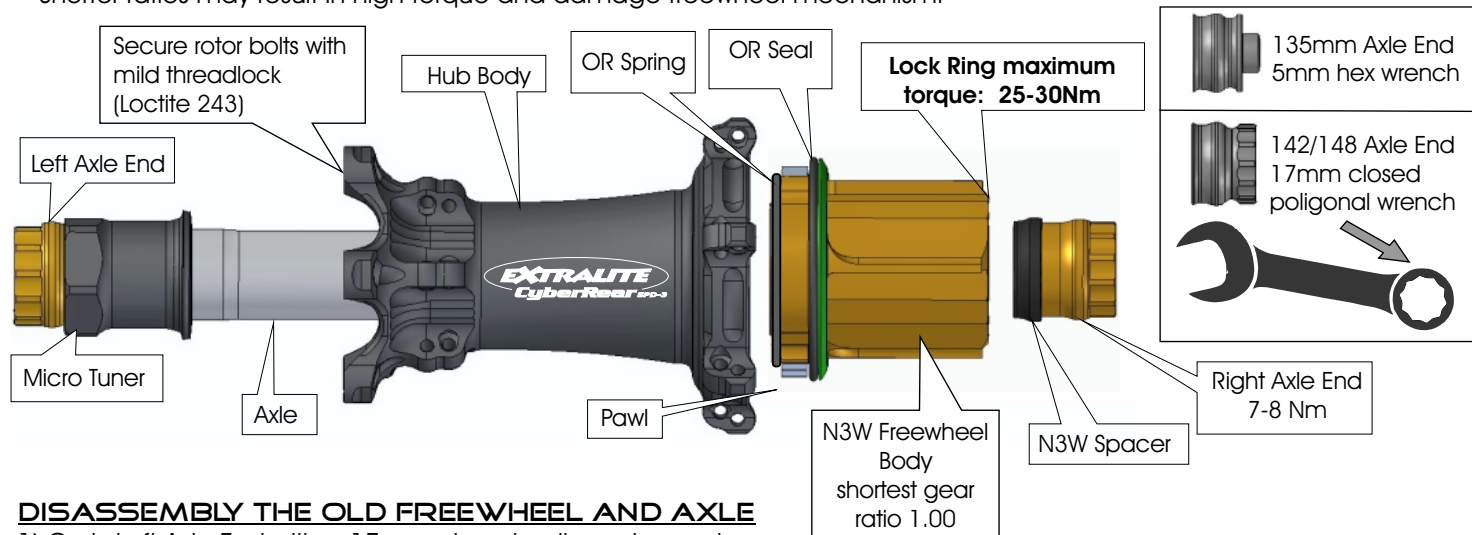

## DISASSEMBLY THE OLD FREEWHEEL AND AXLE

- 1) Grab Left Axle End with a 17mm closed polygonal wrench.
- 2) Unscrew (1 turn) Micro Tuner. **Do not move Micro Tuner till point 12) to prevent damages.**
- 3) Unscrew Right Axle End with a second hex wrench, pull Freewheel Body and remove it.
- 4) Extract Axle from left side.
- 5) Clean all parts and go to next chapter.

**EXTRALITE**

## NEW FREEWHEEL AND AXLE LUBRIFICATION AND ASSEMBLY

- 6) Slightly grease bearing contact surfaces on Axle.
- 7) Grease ratchet wheel with 2cc. of very soft density grease as original Alugrease Super1. Never use Lithium, additivated nor thick grease.
- 8) Oil OR-Seal with thin oil. Oils that are thicker than W40 engine oil may increase freewheel resistance.
- 9) Gently push Axle from right side using a plastic mallet.
- 10) Inserting Freewheel body: check the OR seal, OR Spring and Pawls are correctly positioned, carefully press pawls one by one and partially insert freewheel. Check that pawls engage ratchet wheel properly then insert completely. **Do not pinch seal OR**
- 11) Grese threads and tighten Right Axle End at 7-8 Nm.
- 12) Gently fully screw in Micro Tuner and unscrew it for 1/4 to 1/2 of turn to release excessive preload on bearing balls.
- 13) Set-up bearing preload with preload tuning, see below.
- 14) Install Cog Lock Ring at a maximum torque of 25-30Nm.

### BEARING PRELOAD SET-UP:

Optimal bearing preload is important for a long bearing life.

Micro Tuner comes pre-adjusted from the factory. Do not modify its position if not necessary.

### Checking

Before modifying bearing preload carefully check the complete wheel as follows:

- 1) Install wheel into dropouts and normally lock skewer.
- 2) Check there is no play at rim diameter.
- 3) Leave wheel free to completely stop spinning and carefully control latest instants of movement. Stopping should be very smooth.

### Preload Tuning

If necessary fine tune as follows.

- 1) Install wheel into dropouts and normally lock skewer.
- 2) If you feel play at the rim turn in Micro Tuner (clockwise). Use a 21mm wrench, use very delicate torque.
- 3) Unscrew Micro Tuner for ca 1/4 of turn to release excessive preload on bearing balls and achieve max rolling smoothness.
- 4) Repeat Preload Checking and eventually slightly correct it.
- 5) The optimal bearing preload cancels play at the rim without affecting rolling smoothness.

**Warning** Incorrect bearing preload can damage bearings and freewheel parts additionally decreases hub performance.