

# UltraPost

## FEATURES

Carbon friendly saddle rails.

Destination: X-Country and Road use only.

## COMPATIBILITY

Clamps are designed to accept standard round and oval rails. **WARNING:** Never exceed 9mm distance between rear upper clamp and pivot.

## INSTALLATION

- 1) Position saddle rails between upper and lower clamps (be careful for front and rear side).
  - 2) Screw in front clamp bolt to reach correct position (rear bolt must be loose).
  - 3) Tight rear bolt (**Max torque 3.5 Nm**).
- WARNING:** overtightening bolts may damage clamps and be very dangerous for your safety.

## ADJUSTMENT

To adjust saddle angle turn titanium bolts as follow:  
(example: lowering saddle nose)

- 1) Unscrew rear bolt 1 turn
  - 2) Screw in front bolt 1 turn
- Repeat 1 & 2 until saddle has right angle.

**Maximum torque: 3.5 Nm**

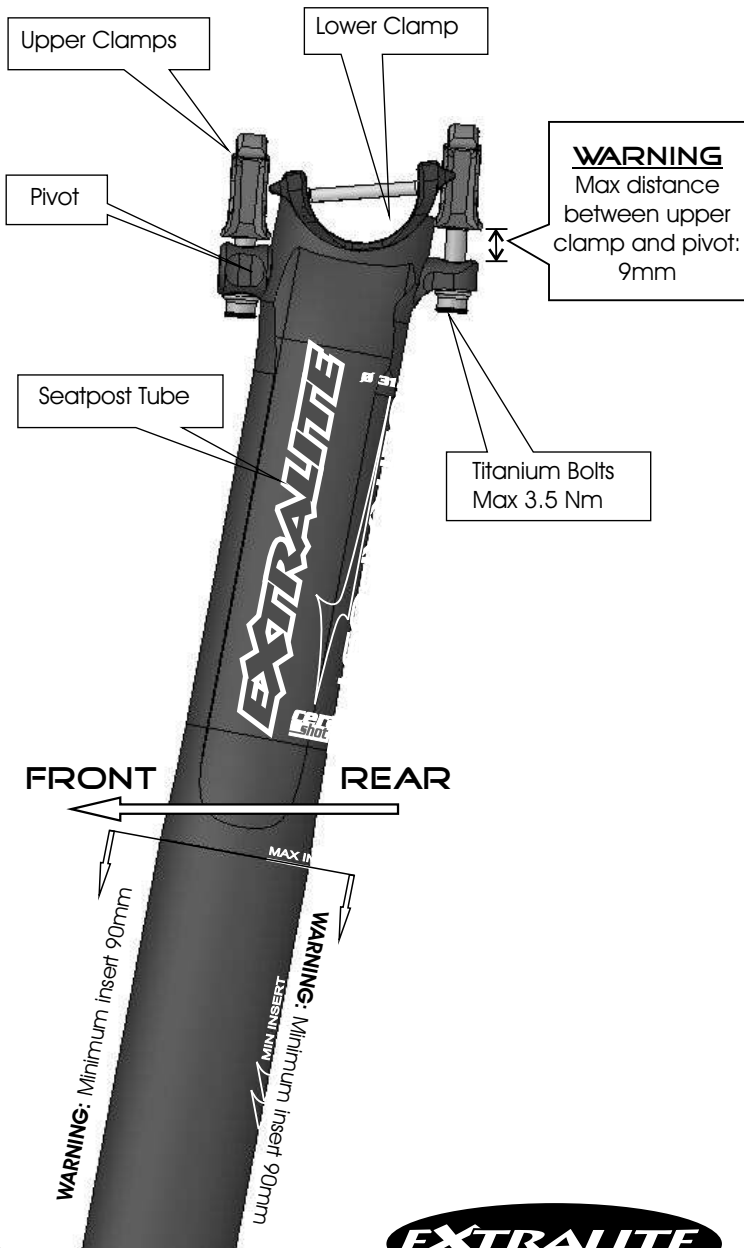

Studio Riva SRL - Tel: ++39-0371-203059

info@extralite.com - www.extralite.com

## WARNING

Seat post tube insertion have to reach and slightly pass frame junction (horizontal tube and seatstay tubes).

We prudentially recommend a minimum insert of 90mm to prevent possible damages to the frame.



## Extralite Limited Warranty

Extralite products are warranted against defects in materials and/or workmanship for a period of two years from original date of purchase to the original owner only.

Any Extralite product that is returned and found by Studio Riva to be defective in materials and/or workmanship will be repaired or replaced at the sole discretion of Studio Riva. This warranty is the sole and exclusive remedy.

Studio Riva shall not be held liable for any indirect, special or consequential damages.

The warranty is expressly limited to repair or replacement of the product that has been returned and found to be defective by Studio Riva and are the sole remedy of the warranty.

No credits or refunds will be issued.

The warranty does not cover: normal wear, tear and fatigue; damage or failure due to accident or collision. Improper assembling, poor maintenance, alterations or modifications, installation of parts not compatible with Extralite products void this warranty.

Warranty does not cover damage arising from crash, abuse and/or misuse or any other circumstances in which the product had been subjected to forces or loads beyond its design.

Immediately replace the component after crash and violent shock, or after continuous heavy use.

Improper use, modification and/or part changing, including surface finishing, could irreparably damage the component.

All labor charges for warranty service are responsibility of the product owner.

## INSTALLATION WARNING:

Extralite components are extremely performing and lightweight, crafted with very high quality, they request adequate installation and maintenance care.

We strongly recommended that a professional bike shop install and service your Extralite components.

Improper assembly and/or adjustment may significantly compromise strength and durability of the component causing serious personal injury.

Carefully check proper tightening torque of every bolt.

Always respect installation recommendations.

Extralite components are designed for a specific use X-Country or Road or Downhill, respect product specific destination.

Note: the rider assumes all the risks regarding use and installation of Extralite components.