

# TA 12 Adaptor Kit

## Description.

This kit adapts HyperFront QR 15 into 12mm Thru Axle.

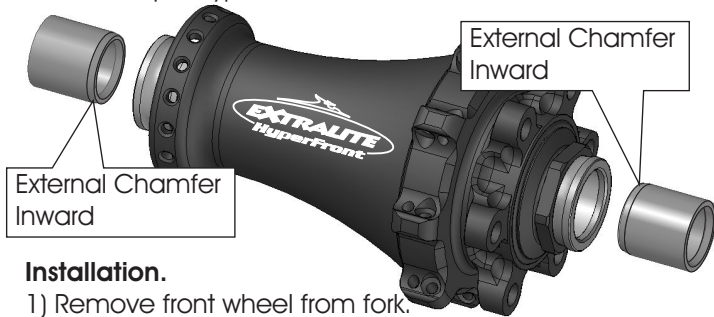

## Installation.

- 1) Remove front wheel from fork.
- 2) Lean one Axle End onto a solid surface.
- 3) Completely insert one bushing by hand pressure or plastic mallet (keep external chamfer inward).
- 4) Flip the wheel and repeat the operation on the other side.

**EXTRALITE**