

UltraStar 4

FEATURES:

Fits alloy or carbon steer tubes, standard M6 top cap bolts.

Versions:

-> **1-1/8'** steer tubes with 22.8 to 25.2 mm internal diameter.

-> **1-1/4'** steer tubes with 25 to 27.2 mm internal diameter.

Destination: Road, Cyclo-cross, X-Country, Trail ride.

WARNINGS:

UltraStar4 should be used only for the tuning of headset bearings, their preload requires the mild torque of 2Nm max. On carbon fiber steer tubes never install UltraStar4 without a stem properly locked onto the tube.

Always remember to tighten stem clamp before riding.

(Respect manufacturer recommended torque).

UltraStar4 cannot hold a loose stem while riding.

EXTRALITE LIMITED WARRANTY:

See Web-Shop <http://webshop.extralite.com> terms and conditions.



INSTALLATION:

File the top of the steer-tube to avoid sharp edges.

Degrease well internal surface of steer-tube an sand paper with 250-400 grit.

Hold Lower Cone with your fingers.

Use 8mm allen key to screw in Top Cone until you can fully insert UltraStar4 into the steer tube with mild hand pressure.

Insert and tighten UltraStar4 (7-8Nm) in the steer tube at 5 to 10mm from the top.

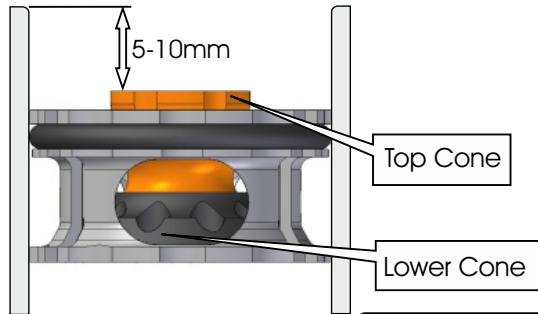

EXTRALITE